

## FlashEA® 1112 CHN / CHNS / Oxygen Automatic Elemental Analyzer



### For reliable and precise CHN, CHNS and Oxygen determination

The FlashEA 1112 from Thermo Fisher Scientific, a modern and compact analyzer designed for unattended and full determination of CHN, CHNS and Oxygen in any type of sample from solid to liquid, has been the result of almost four decades of experience and innovations.

With the introduction of the Carlo Erba 1100, the first fully automated analyzer back in 1968, our activity in the Organic Elemental Analysis field had since been marked by an outstanding track record of continuous innovation and unsurpassed product quality.

Since the late sixties our R&D lab has provided many breakthroughs in the development of materials, catalyst and technical solutions which made the Dynamic Flash Combustion method in Organic Elemental Analysis today, a leading standard for accuracy and precision in the determination of Nitrogen, Carbon, Hydrogen and Sulfur.

One of the strengths of the FlashEA 1112 is the Eager 300 dedicated software: An intelligent tool able to satisfy every analytical request (i.e. evaluate and present the data, personalized analytical reporting, and dedicated features for QC labs).

#### Officially endorsed

The validity of the FlashEA method is endorsed by renowned international committees (AOAC, ASTM and others). The simplicity of the method, unparalleled data reproducibility and truly quantitative results is the essence of its wide acceptance by many official organizations.

The quality of FlashEA data is certified to meet the numerous international round robin tests implemented for every type of material.



*Your samples,  
our experience*



### Accurate, simultaneous CHNS determination

The FlashEA 1112 has streamlined all steps required to achieve precise determination of Carbon, Hydrogen, Nitrogen, and Sulfur.

The sample is weighed in Tin capsules, placed inside the MAS 200R autosampler at a preset time, and then dropped into an oxidation / reduction reactor kept at a temperature of 900 – 1000 °C. The exact amount of Oxygen required for optimum combustion of the sample is delivered into the combustion reactor at a precise time. The reaction of Oxygen with the Tin capsule at elevated temperature generates an exothermic reaction which raises the temperature to 1800 °C for a few seconds. At this high temperature both organic and inorganic substances are converted into elemental gases which, after further reduction, are separated in a chromatographic column and finally detected by a highly sensitive thermal conductivity detector (TCD).

The FlashEA 1112 is not a *black box* instrument: the GC separation column is an open window on the analytical system; in fact the chromatogram (peak shape, peak separation, peak retention time etc.) demonstrates the real status of the instrument in every condition.

The highest degree of accuracy is ensured by the complete conversion of the total sample to the elemental gases without dilution or splitting therefore without the presence of gas chambers or adsorption & desorption traps.

### Versatile, precise Oxygen determination

Reliable Oxygen determination is achieved through an Oxygen-specific pyrolysis reactor heated at a temperature slightly above 1060 °C. This allows a complete pyrolysis of the sample in an oxidant-free environment.

A "Nickel coated Carbon" catalyst, specifically developed for this application, ensures unprecedented precision and accuracy with a substantial reduction of analysis costs.

The highly versatile FlashEA is supplied either with a double reactor configuration arranged for simultaneous CHN and/or CHNS and Oxygen analysis, or with a single reactor for CHN or CHNS.

Upgrading to a double reactor configuration can be easily performed on site when the need arises, since the analyzer is prearranged to quickly incorporate this option.

### Sulfur trace by FPD

To obtain trace Sulfur determinations it is possible to couple a specific Sulfur detector (Flame Photometric Detector - FPD) to the FlashEA. Using this special system it is possible to reach 5 - 10 ppm of Sulfur; opening a new pathway in classical Organic Elemental Analysis (OEA) analysis for organic and inorganic compounds.

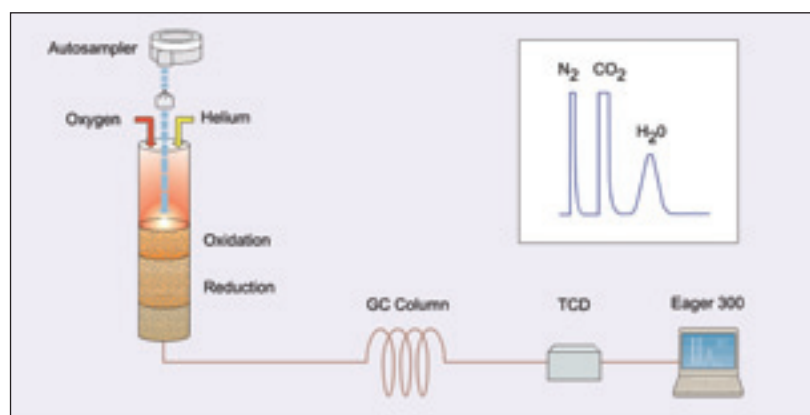

CHN

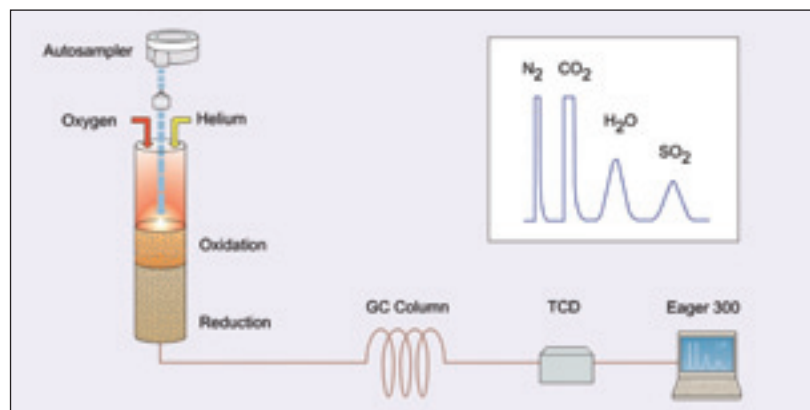

CHNS

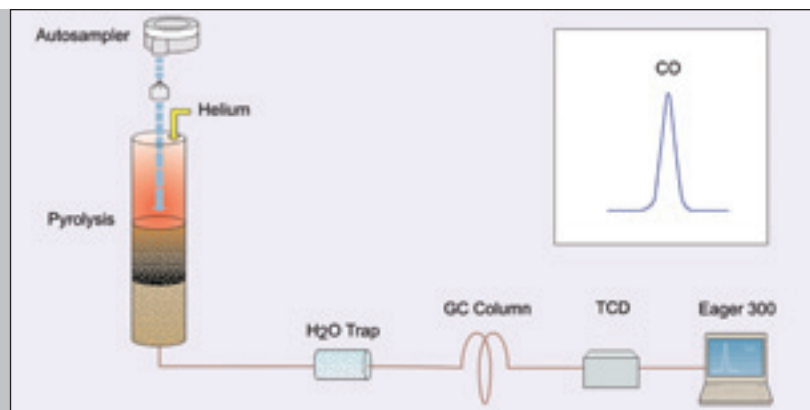

Oxygen

## Modularity

Among the features of the FlashEA instrument is the great modularity of the sample introduction system:

## Universal Autosampler

The MAS 200R is typically configured with a 32-sample tray, but can accept further 3 drums. In this way, MAS 200R sample capacity reaches 125 samples and it becomes a useful tool for the lab which must analyze several samples every day.

## Liquid Autosamplers

Thermo Fisher provides two liquid autosamplers suitable for all FlashEA 1112 configurations: the AI 3000 and AS 3000.

The AI 3000 has an 8-sample tray while the AS 3000 boasts a 105 position tray. Both liquid autosamplers are robust, precise, easy to install and easy to use.

## Change of application?

The modular design of the FlashEA 1112 CHNS analyzer means that laboratories can easily change the configuration to any other Thermo Scientific OEA analyzer, according to their needs.



FlashEA 1112, MAS 200R and AS3000 Autosamplers

## Eager 300 software – the most complete OEA software package

The Eager 300 software is a powerful complement to the FlashEA 1112. Compatible with the current Windows system, Eager 300 is the comprehensive and highly flexible software platform offering different levels of access to either all the available features or only to customized and simplified user-interfaces.

## A variety of calibration methods ensures proper quantitation

Element percentage in a sample is precisely calculated either using the average K-factor method for a single point or the linear fit method for multipoint standard concentrations. For special applications, such as trace Sulfur using the FPD detector, a non-linear fit method can better represent the shape of the calibration curve.

## Some of the other Eager 300 software functions include:

- Pre-set OEA methods
- Intuitive program pages - enabling quick reference to method parameters and instrument status readout
- Automatic Oxygen Dosing System using the Flow Controller
- Automatic Leak Check
- User compound library
- Minimized maintenance downtime
- Integrated and simplified user interface
- Maintenance Status under control
- Green/Red light function for QC applications
- Automatic calculation of GHV (Gross Heat Value) and NHV (Net Heat Value) for solid and liquid fuels and for alternative fuels
- Automatic evaluation of the Empirical Formula for fine chemicals and pharmaceutical products
- Powerful and personalized analytical report publisher
- Possibility to integrate into a LAN (Local Area Network) connection
- Compatibility with various Laboratory Information Management Systems (LIMS)
- Data export into ASCII file or Excel summary results file

Eager 300 software supports compliance to strict FDA regulations (CFR 21 part 11) for a closed analytical system.

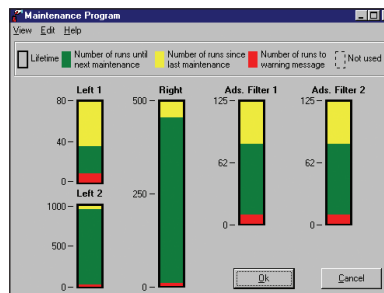

Eager 300 Maintenance Status



## Organic Materials

	N %	C %	H %	S %
dl-Methionine	9.41	40.24	7.43	21.42
RSD%	0.39	0.29	0.32	0.49
Theoretical value	9.39	40.25	7.43	21.49
<b>BCR 71</b>	<b>10.86</b>	<b>40.55</b>	<b>2.32</b>	<b>8.18</b>
RSD%	0.495	0.236	0.51	0.88
Theoretical value	10.85	40.39	2.37	8.30
<b>BCR 72</b>	<b>9.647</b>	<b>36.13</b>	<b>2.078</b>	<b>7.344</b>
RSD%	0.35	0.09	0.40	0.91
Theoretical Value	9.65	36.13	2.10	7.35

Sample weight: 2 – 3 mg

No. of analysis: 10

BCR 71: N-(4-bromophenyl)-N'-(2-chloro-4-nitrophenyl) thiourea

BCR 72: N-(2-chloro-4-nitrophenyl)-N'-(2-iodophenyl) thiourea

## Petrochemistry

	N %	C %	H %	S %	O %	G.H.V.	N.H.V.
<b>South African</b>							
Coal	1.1	68.35	4.89	0.212	16.38	7293.55	7042.81
RDS%	0.35	0.09	0.40	0.91	0.847	0.34	0.33
<b>Coke</b>	<b>2.183</b>	<b>89.4</b>	<b>3.266</b>				
RSD%	1.17	0.38	0.83				

Sample weight: 2 – 3 mg

No. of analysis: 10

G.H.V. : Gross Heat Value (Kcal / Kg)

N.H.V. : Net Heat Value (Kcal / Kg)

## Material Characterization

	N %	C %	H %	S %
<b>Tyres A</b>	<b>0.5738</b>	<b>84.7714</b>	<b>7.8326</b>	<b>1.9753</b>
RSD%	0.7299	0.2059	0.1743	0.9279
<b>Tyres B</b>	<b>0.4796</b>	<b>89.9350</b>	<b>7.9260</b>	<b>0.8812</b>
RSD%	0.5214	0.2234	0.1647	1.8431

Sample weight: 2 – 3 mg

No. of analysis: 10

## Environmental Analysis

	N %	C %	H %	S %	O %
<b>Compost A</b>	<b>1.5401</b>	<b>40.8423</b>	<b>5.6829</b>	<b>0.4959</b>	<b>34.22</b>
RSD%	1.994	0.153	0.3352	1.8353	0.6612
<b>Compost B</b>	<b>1.8553</b>	<b>39.859</b>	<b>5.1919</b>	<b>0.583</b>	<b>31.352</b>
RSD%	2.298	0.5687	0.6349	2.1293	0.5657

Sample weight: 3 – 4 mg

No. of analysis: 5

## Sulfur determination by FPD (Flame Photometric Detector)

	S ppm	Average S ppm	RSD %
<b>Clay</b>	59	61	4.103
	61		
	64		
<b>Cellulosa</b>	12	12	4.681
	13		
	12		

Standard: Thermo Fisher Scientific Soil Reference Material (S: 320 ppm)

Standard weight: 1.5 – 5 mg

Sample weight : 2 – 3 mg

Note: the samples have been analyzed with the addition of 5 mg V<sub>2</sub>O<sub>5</sub>

## Validation

Nowadays many companies must comply with extensive industry and government regulations.

Thermo Fisher is pleased to announce the Thermo Scientific FlashEA 1112 is the *first OEA instrument* equipped with a specific qualification package. This package consists of extensive documentation and tailored validation kit(s) according to the instrument configuration (CHNS, CHN, O etc.).

### The FlashEA Validation Package includes:

Declaration of Conformity

Equipments & Determination Profile

Qualifications:

IQ Installation Qualification / OQ Operational Qualification /

PQ Performance Qualification

Declaration of System Validation

Test results

Validation certificate

